

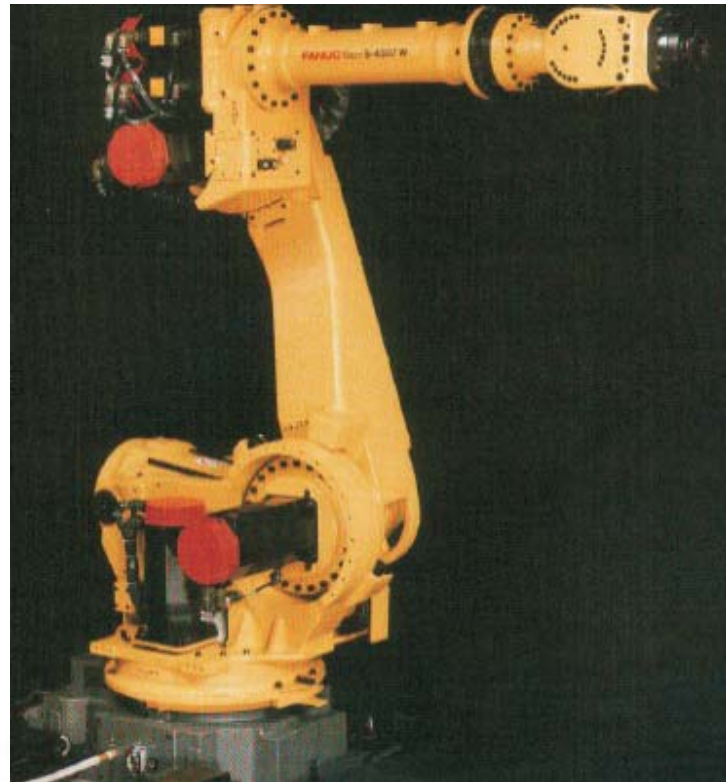

FANUC ROBOTICS S-430i Series

2Ri Robotics carries a wide selection of high-quality used robots, in stock and ready for shipment. Each component has undergone extensive reconditioning and passed rigorous testing to guarantee years of service and dependability



S-430i/W/200kg

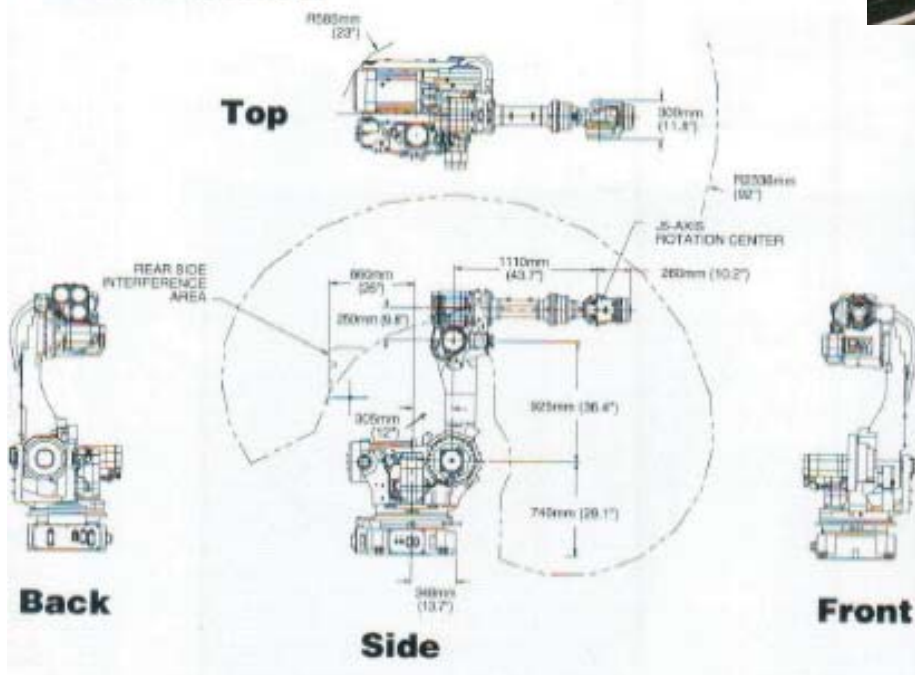

Footprint (All models)

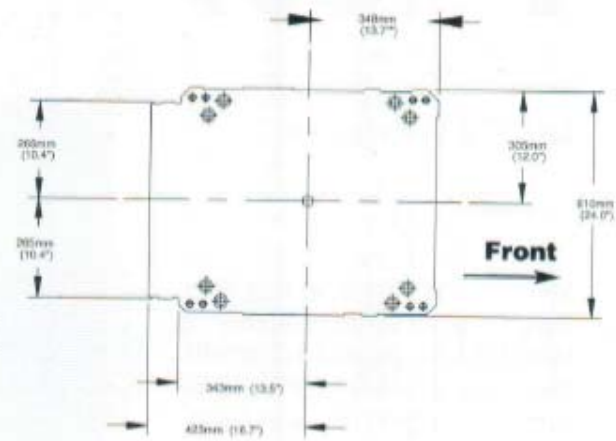

S-430i/F, S-430i/W

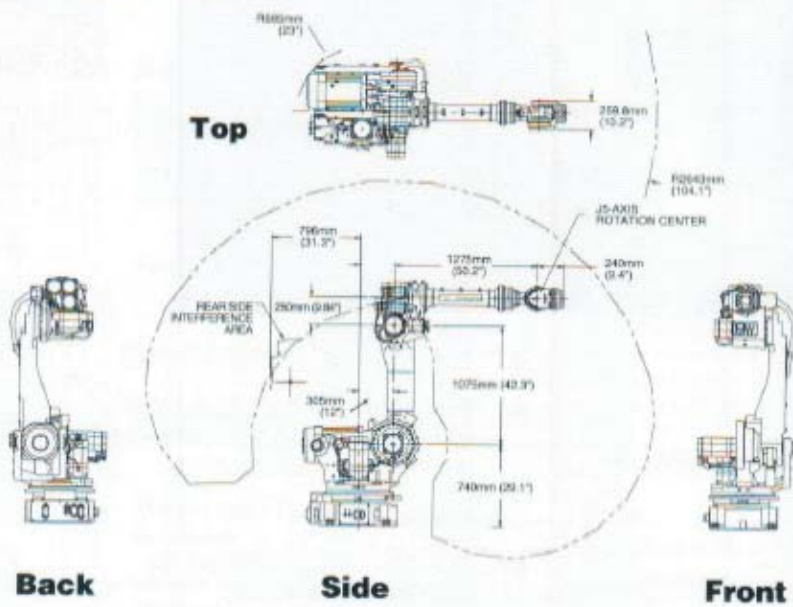

S-430i/L

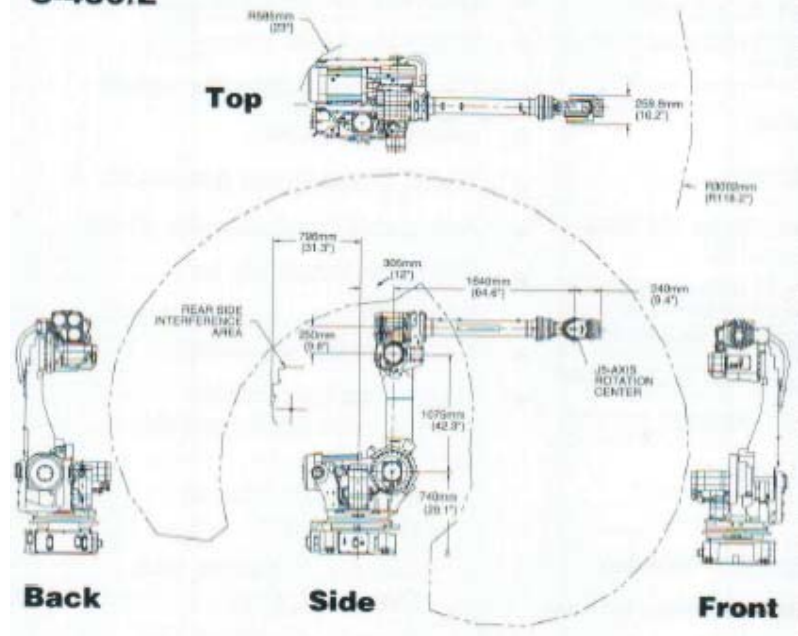

S-430iU

NOTE:
ROBOT CAN PASS IN THE HATCHED AREA,
BUT CAN NOT REST IN THIS AREA

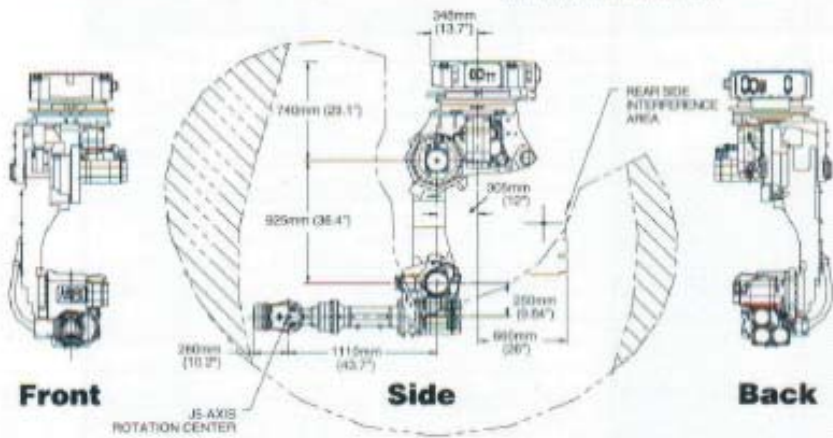

S-430iCF

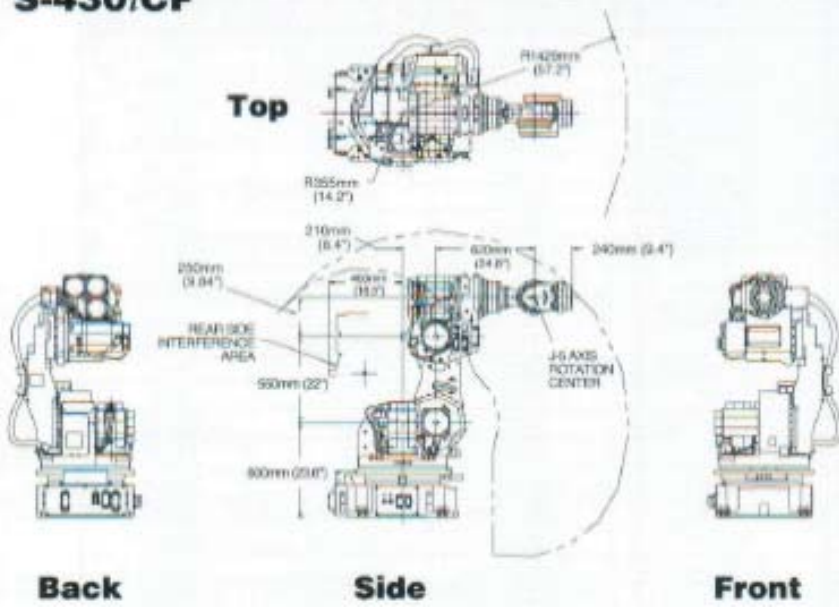

S-430iR

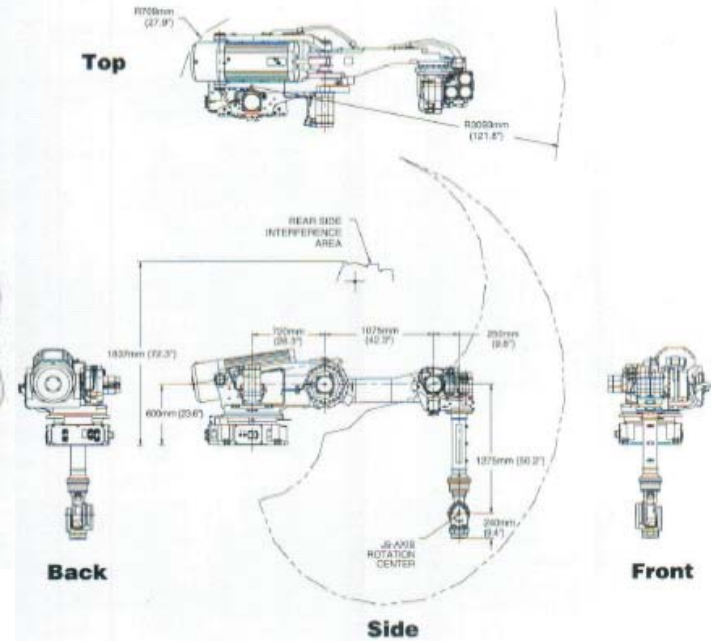

S-430iCI

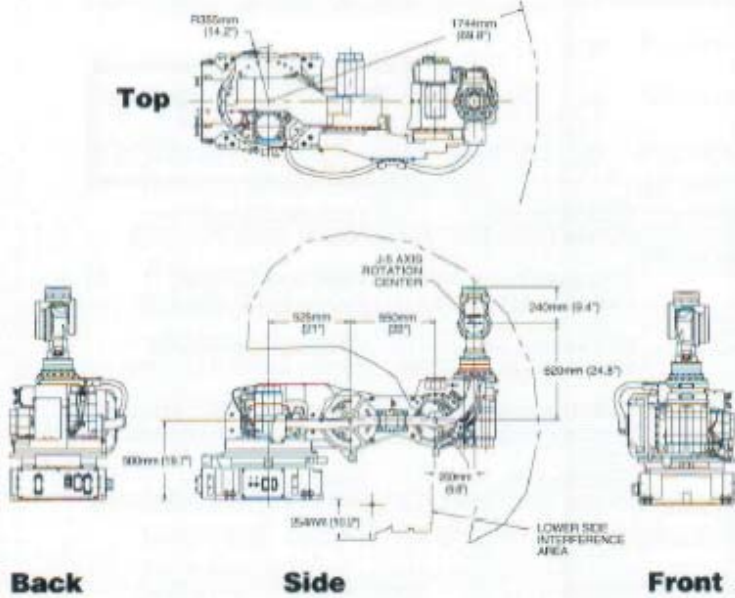

S-430iR/ PHT, S-430iR/ PHS

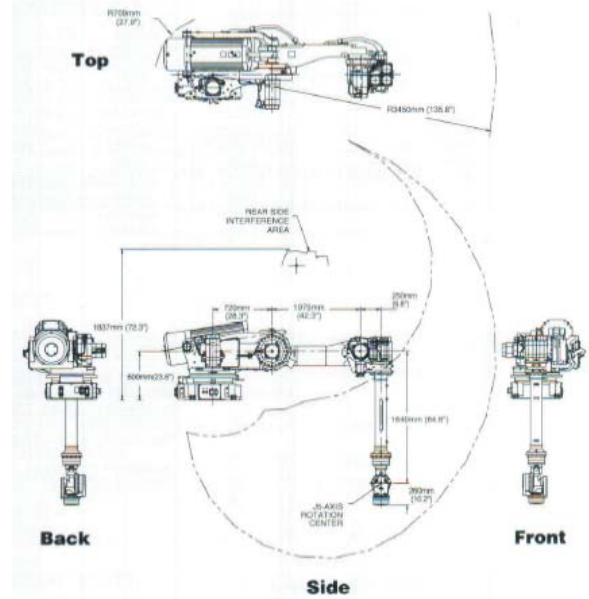

Standard Wrist (S-430iF, W, L, R, U, CI, CF)

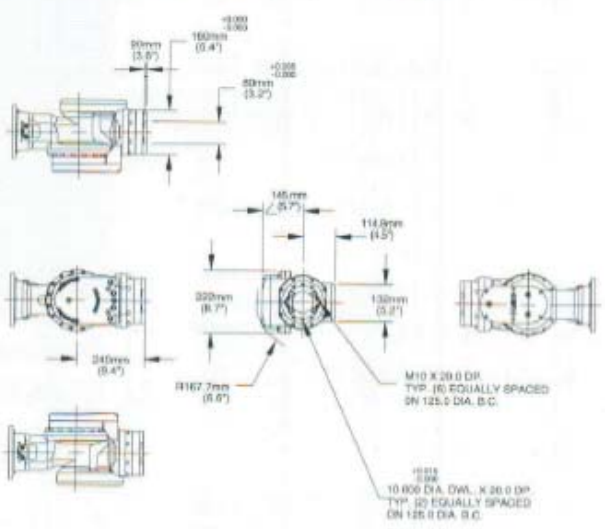

Heavy-Duty Wrist (S-430iR/ PHT, R/ PHS, W/200, iU)

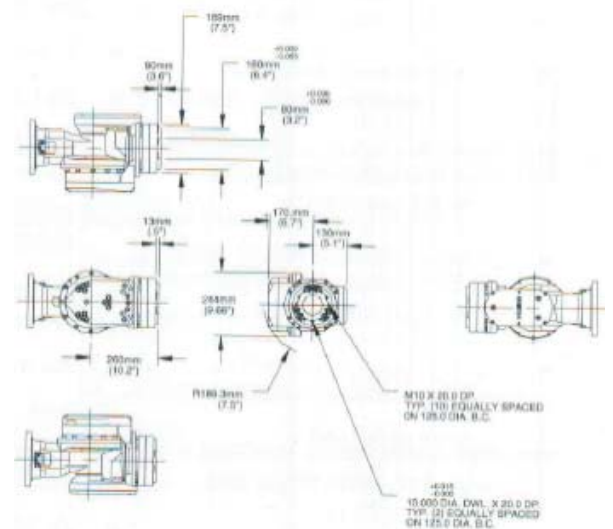

Isometric

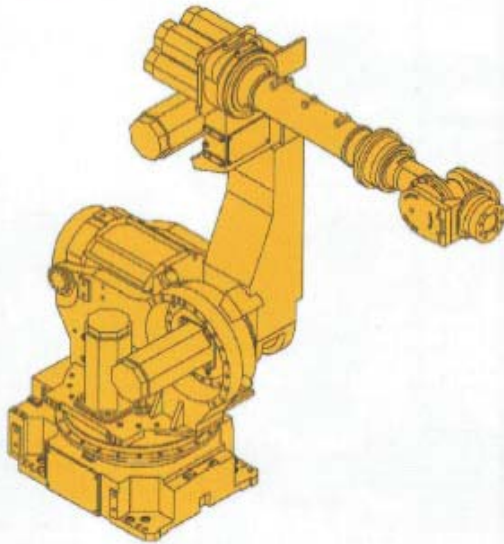

S-430i Specifications

Specifications	S-430iF	S-430iW	S-430iW/200	S-430iL/80	S-430iL/125	
Payload	130kg (286 lbs)	165kg (363 lbs)	200kg (441 lbs)	80kg (176 lbs)	125kg (275 lbs)	
Reach	2643mm (104')	2643mm (104')	2336mm (92')	3002mm (118')	3002mm (118')	
Interference radius	R585mm	R585mm	R585mm	R585mm	R585mm	
Motion speed	J1 axis	110°/sec	105°/sec	90°/sec	130°/sec	105°/sec
	J2 axis	110°/sec	105°/sec	90°/sec	130°/sec	105°/sec
	J3 axis	100°/sec	105°/sec	90°/sec	130°/sec	105°/sec
	J4 axis	210°/sec	130°/sec	110°/sec	200°/sec	170°/sec
	J5 axis	150°/sec	130°/sec	110°/sec	170°/sec	170°/sec
	J6 axis	210°/sec	210°/sec	150°/sec	310°/sec	260°/sec
Motion range	J1 axis	360°	360°	360°	360°	360°
	J2 axis	134°	134°	134°	134°	134°
	J3 axis	362°	362°	335°	352°	352°
	J4 axis	720°	720°	720°	720°	720°
	J5 axis	250°	250°	250°	250°	250°
	J6 axis	720°	720°	720°	720°	720°
Allowable wrist load moment	J4 axis	70kgfm	93kgfm	130kgfm	60kgfm	60kgfm
	J5 axis	70kgfm	93kgfm	130kgfm	60kgfm	60kgfm
	J6 axis	35kgfm	46kgfm	70kgfm	35kgfm	35kgfm3
Allowable wrist load inertia	J4 axis	417kgfcm ²	900kgfcm ²	1200kgfcm ²	600kgfcm ²	600kgfcm ²
	J5 axis	417kgfcm ²	900kgfcm ²	1200kgfcm ²	600kgfcm ²	600kgfcm ²
	J6 axis	104kgfcm ²	450kgfcm ²	600kgfcm ²	200kgfcm ²	230kgfcm ²
Repeatability	±0.3mm	±0.3mm	±0.3mm	±0.3mm	±0.3mm	
Mounting method	Upright	Upright	Upright	Upright	Upright	
Mechanical brakes	All axes	All axes	All axes	All axes	All axes	
Weight	1300kg	1300kg	1300kg	1300kg	1300kg	
Purpose	Floor mount	Heavy duty floor mount	Extra Heavy duty floor mount	Long arm floor mount	Heavy duty long arm floor mount	

S-430i Specifications cont.

Specifications	S-430iR/130	S-430iR/165	S-430iR/PHT	S-430iR/PHS	S-430iU	S-430iCF	S-430iCI	
Payload	130kg (286 lbs)	165kg (363 lbs)	130kg (286 lbs)	130kg (286 lbs)	130kg (286 lbs)	165kg (363 lbs)	165kg (363 lbs)	
Reach	2643mm (104')	2643mm (104')	3450mm (133')	3450mm (133')	2336mm (92')	1418mm (55.8')	1716mm (67.5')	
Interference radius	R585mm	R585mm	R709mm	R709mm	R585mm	R355mm	R355mm	
Motion speed	J1 axis	110°/sec	105°/sec	118°/sec	118°/sec	90°/sec	110°/sec	110°/sec
	J2 axis	90°/sec	90°/sec	90°/sec	90°/sec	90°/sec	90°/sec	90°/sec
	J3 axis	100°/sec	105°/sec	105°/sec	105°/sec	90°/sec	100°/sec	100°/sec
	J4 axis	210°/sec	130°/sec	114°/sec	180°/sec	110°/sec	130°/sec	130°/sec
	J5 axis	150°/sec	130°/sec	114°/sec	180°/sec	110°/sec	130°/sec	130°/sec
	J6 axis	210°/sec	210°/sec	160°/sec	285°/sec	150°/sec	210°/sec	210°/sec
Motion range	J1 axis	360°	360°	360°	360°	360°	360°	360°
	J2 axis	129°	129°	129°	129°	134°	165°	165°
	J3 axis	238.5°	238.5°	238.5°	238.5°	345°	250°	210°
	J4 axis	720°	720°	720°	720°	720°	720°	720°
	J5 axis	250°	250°	250°	250°	250°	250°	250°
J6 axis	720°	720°	720°	720°	720°	720°	720°	
Allowable wrist load moment	J4 axis	70kgfm	93kgfm	150kgfm	93kgfm	70kgfm	93kgfm	93kgfm
	J5 axis	70kgfm	93kgfm	146kgfm	92kgfm	70kgfm	93kgfm	93kgfm
	J6 axis	35kgfm	46kgfm	101kgfm	56kgfm	35kgfm	46kgfm	46kgfm3
Allowable wrist load inertia	J4 axis	417kgfcm ²	900kgfcm ²	4200kgfcm ²	3900kgfcm ²	417kgfcm ²	900kgfcm ²	900kgfcm ²
	J5 axis	417kgfcm ²	900kgfcm ²	4200kgfcm ²	3800kgfcm ²	417kgfcm ²	900kgfcm ²	900kgfcm ²
	J6 axis	104kgfcm ²	450kgfcm ²	2100kgfcm ²	1400kgfcm ²	104kgfcm ²	450kgfcm ²	450kgfcm ²
Repeatability	±0.3mm	±0.3mm	±0.4mm	±0.4mm	±0.3mm	±0.3mm	±0.3mm	
Mounting method	Shelf	Shelf	Shelf	Shelf	Inverted	Upright	Upright	
Mechanical brakes	All axes	All axes	All axes	All axes	All axes	All axes	All axes	
Weight	1600kg	1600kg	1600kg	1600kg	1200kg	1050kg	1100kg	
Purpose	Rack mount	Heavy duty rack mount	High torque rack mount	High speed rack mount	Invert mount	Compact floor mount	Compact floor mount	