



**FANUC
ROBOTICS
M-420iA/
M-421iA**

2Ri Robotics carries a wide selection of high-quality used robots, in stock and ready for shipment. Each component has undergone extensive reconditioning and passed rigorous testing to guarantee years of service and dependability

M-420iA/M-421iA Specifications

Items		M-420iA	M-421iA
Axes		4	2
Payload - Wrist (kg)		40	50
- J3 Arm (kg)		10	10
Reach (mm)		1855	1855
Repeatability (mm)		± 0.5	± 0.5
Interference radius (mm)		543	-
Motion range (degrees)	J1	320	-
	J2	115	115
	J3	110	110
	J4	540	-
Motion speed (degrees/sec.)	J1	180	-
	J2	200	200
	J3	200	200
	J4	350	-
Wrist moment (kgf-m)	J4	10	10
Wrist inertia (kgf-cm-s ²)	J4	26	26
Mechanical brakes	All axes	All axes	
Mechanical weight (kg)	620	520	
Mounting method	Floor		
Installation environment			
Ambient temperature °C	0 to 45		
Humidity	Normally: 75% or less Short term (within a month): 95% or less No condensation		
Vibration (m/s ²)	4.9 or less		

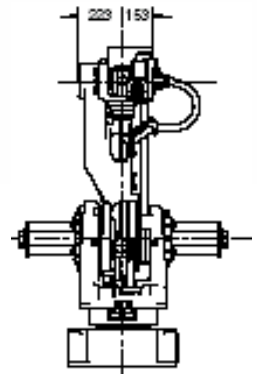
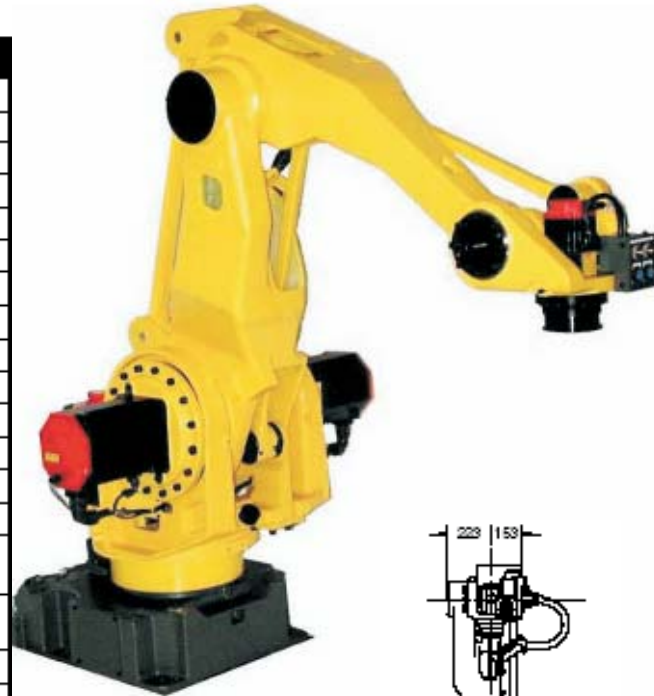

Front

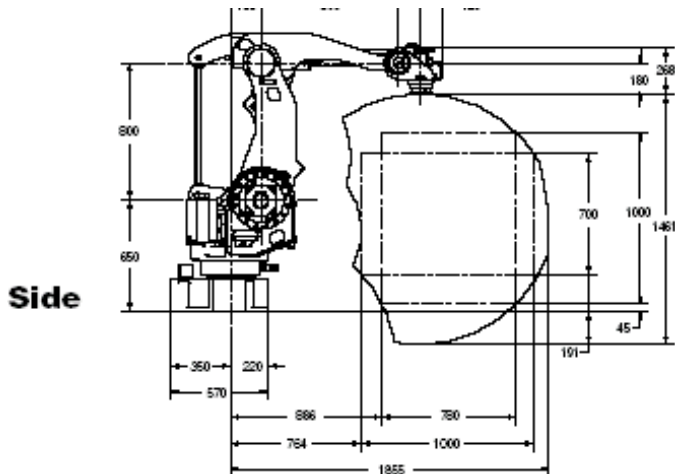

Side

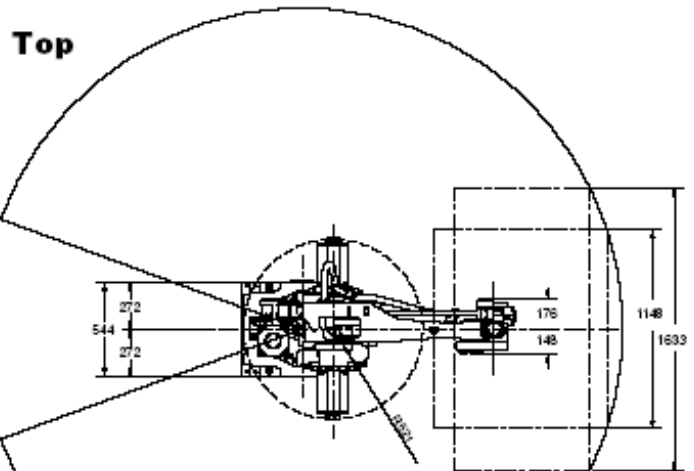

Top