



## FANUC ROBOTICS M-16iL

2Ri Robotics carries a wide selection of high-quality used robots, in stock and ready for shipment. Each component has undergone extensive reconditioning and passed rigorous testing to guarantee years of service and dependability

### M-16i/iL Specifications

Items		Range	Speed
		M-16i/M-16iL	M-16i/M-16iL
Motion range and speed (1)	Axis 1	330°	140°/sec
	Axis 2	240°	140°/sec
	Axis 3	455.5°/410°	140°/sec
	Axis 4	400°	330°/sec
	Axis 5	280°	330°/sec
	Axis 6	900°	450°/sec
Moment kgf • m (N • m)		<b>M-16i</b>	<b>M-16iL</b>
	Axis 4	3.6 (35.1)	2.2 (22.0)
	Axis 5	3.2 (31.4)	2.0 (19.6)
Load inertia kgf • cm • s <sup>2</sup>	Axis 6	1.6 (15.7)	1.0 (9.8)
	Axis 4	8.7	5.3
	Axis 5	7.1	4.3
Axis 6	2.0	1.2	
Repeatability mm (in)		±0.08(±0.003)	±0.1(±0.004)
Maximum load capacity kg (lbs)	Wrist	16 (35.2)	10 (22.0)
	Axis 3	20 (44)	12 (26.4)
	Axis 2	30 (66)	30 (66.0)
Maximum reach mm (in)		1805 (63.2)	1813 (71.4)
Horizontal stroke mm (in)		1073 (42.2)	1329 (52.3)
Mounting method <sup>1</sup>	Upright, inverted, angle and wall		
Mechanical brakes	All axes		
Mechanical weight	270kg (594 lbs)		
i-Controller weight	100kg		
Levels of protection	Wrist and joint	IP67	
	3 arm		
	Body	IP54(IP55 optional)	
	Controller	IP54	

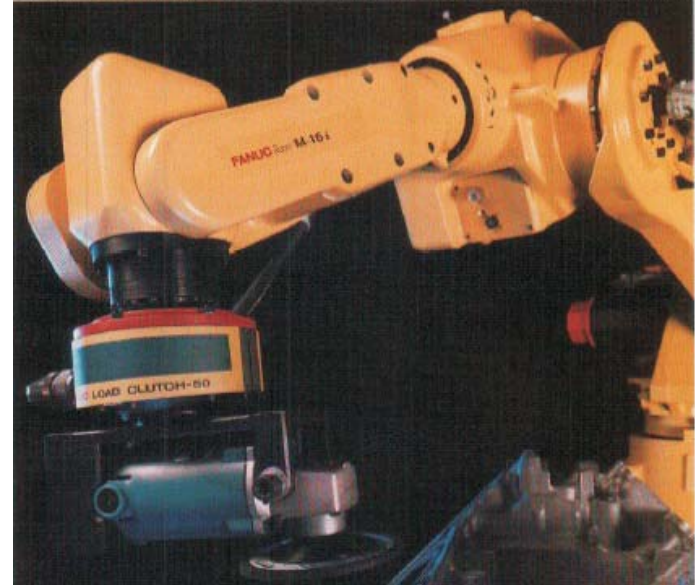

### Side (M-16iL)

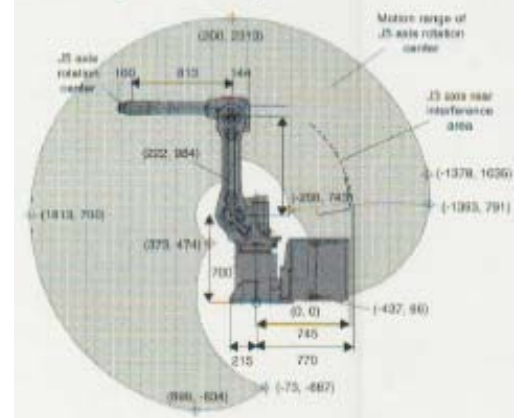

### Front

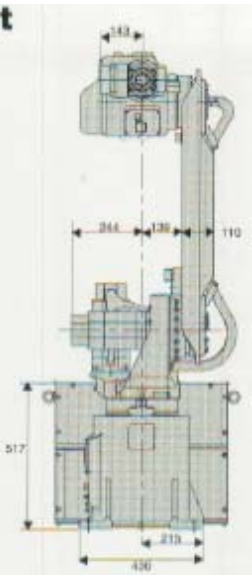

### Top

