



## FANUC ROBOTICS M-16iB/20LT

2Ri Robotics carries a wide selection of high-quality used robots, in stock and ready for shipment. Each component has undergone extensive reconditioning and passed rigorous testing to guarantee years of service and dependability

### M-16iB/20T Specifications

Items		
Axes		6
Payload - wrist (kg)		20
- J3 arm (kg)		12
Reach (mm)		1517
Repeatability (mm)		± 0.10
Interference radius (mm)		234
Motion range (degrees)	J1	2.4 m - 32 m
	J2	300
	J3	460
	J4	400
	J5	280
	J6	900
Motion speed (degrees/s)	J1	2750 mm/sec.
	J2	165
	J3	175
	J4	350
	J5	340
	J6	520
Wrist moment (kgf-m)	J4	4.0
	J5	4.0
	J6	2.0
Wrist inertia (kgf-cm-s <sup>2</sup> )	J4	9.0
	J5	9.0
	J6	2.5
Mechanical brakes	All axes	
Mechanical weight (kg)	147 (Robot arm only)	
Mounting method	Sideslung or underslung	
Installation environment		
Ambient temperature °C	0 to 45	
Humidity	Normally: 75% or less	
	Short term (within a month): 95% or less No condensation (No dew or frost allowed)	
Vibration (m/s <sup>2</sup> )	4.9 or less (0.5g or less)	
IP Rating(s)	Rail IP60, Body IP64, Wrist & J3 arm IP67	
Purpose	Overhead rail mount	



### Top (Underslung)

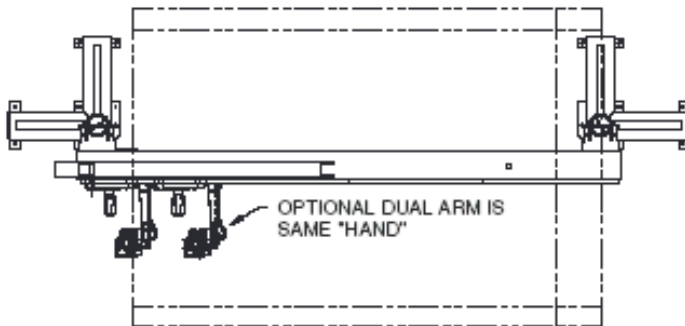

### Top (Sideslung)

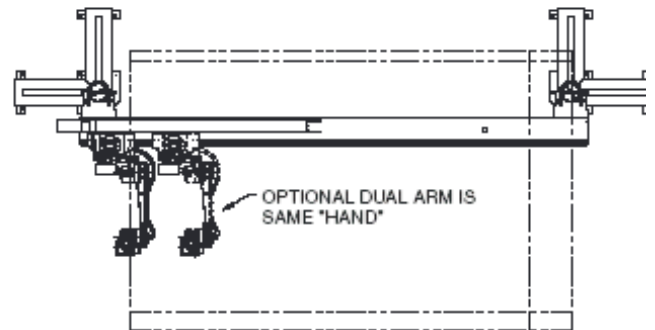

### Front (Underslung)

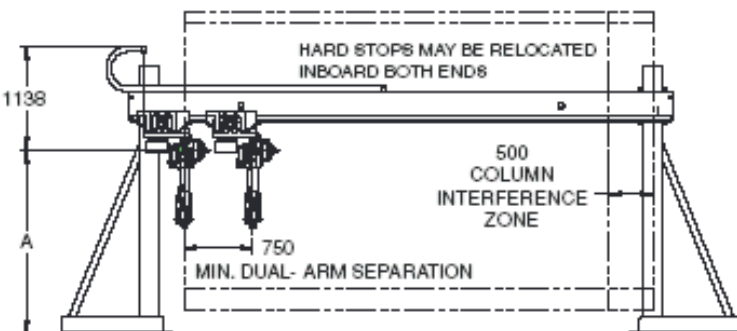

### Front (Sideslung)

