



## FANUC ROBOTICS ArcMate120iL

2Ri Robotics carries a wide selection of high-quality used robots, in stock and ready for shipment. Each component has undergone extensive reconditioning and passed rigorous testing to guarantee years of service and dependability

### ARC Mate 120*i*L Specifications

Items			
		Range	Speed
Motion range and speed	Axis 1	330°	140°/sec
	Axis 2	240°	140°/sec
	Axis 3	455.5°	140°/sec
	Axis 4	400°	330°/sec
	Axis 5	280°	330°/sec
	Axis 6	900°	450°/sec
Wrist load moments (kgf • m)		<b>AM120i</b>	<b>AM120iL</b>
	Axis 4	3.6 (35.1)	2.2 (22.0)
	Axis 5	3.2 (31.4)	2.0 (19.6)
	Axis 6	1.6 (15.7)	1.0 (9.8)
Wrist load inertia (kgf • cm • s <sup>2</sup> )	Axis 4	8.7 (0.85)	5.3 (0.52)
	Axis 5	7.1 (0.70)	4.3 (0.42)
	Axis 6	2.0 (0.20)	1.2 (0.12)
Maximum load capacity, kg (lbs)	Wrist	16 (35.2)	10 (22.0)
	Axis 3	20 (44)	12 (26.4)
	Axis 2	30 (66)	30 (66.0)
Repeatability, mm (in)		±0.08 (±0.003)	±0.1 (±0.004)
Weight	370kg (814 lbs) including integrated i-controller		
Notes:			
(1) Under the installation condition with ( ), the J1 and J2 axis motion range will be limited			
(2) J1 axis 360° 6.28 rad rotation is option			
(3) J2 axis and J3 axis motion range will be limited by the angle of J1 axis			
(4) J6 axis motion range unit is option			

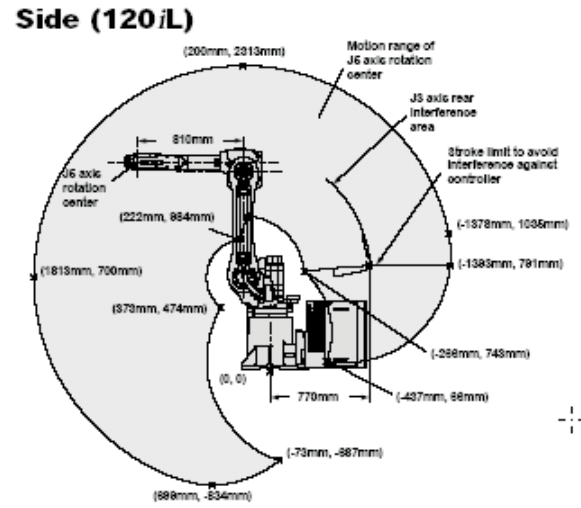
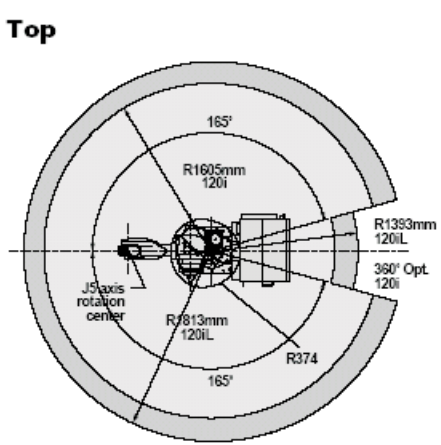
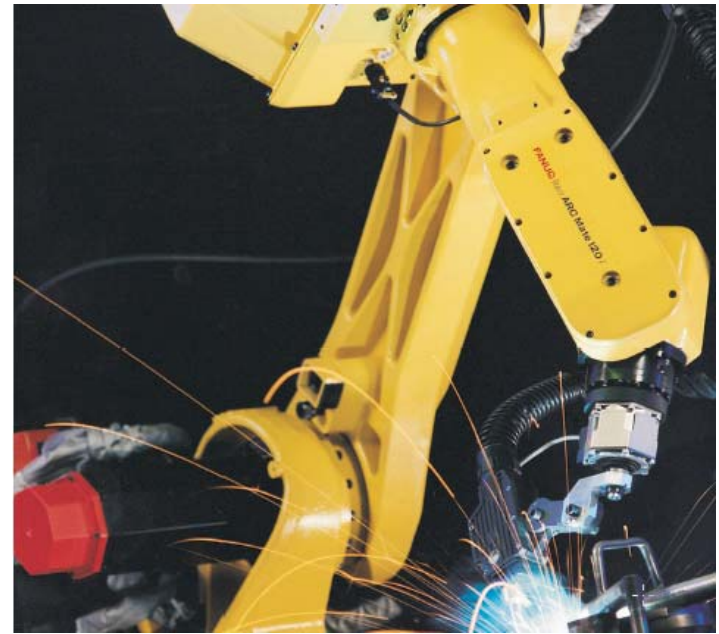

Front

